



(ES)

Los tornillos DIN 444 se utilizan principalmente en utillajes y calderería para realizar conexiones y cierres en el montaje de equipos.

Habitualmente nuestros tornillos con ojo se suministran totalmente roscados para disponer de una mayor área de uso.

También podemos servir tornillos con ojo inoxidable, con otras ejecuciones y especiales bajo consulta.

(EN)

The DIN 444 eyebolts are primarily used as fixture and machine elements to make connections and closures when assembling the equipment.

Our eyebolts normally come fully threaded so that you can use them in a larger area.

We also have stainless steel eyebolts available by request for other configurations.



Tornillos con Ojo
DIN 444 Eye bolts
Vis à Œil
Parafusos com Olhal

FR

Les vis à œil suivant DIN 444 sont principalement utilisées pour les équipements d'assemblage, les fixations et les systèmes de fermeture en chaudronnerie.

Fabrication en acier bruni classe 8.8, finition B et principalement fournies en filetage total pour une plus grande utilisation.

Sur demande vis à œil en inox, autres finitions et sur plan.

PT

Os parafusos DIN 444 são utilizados principalmente em ferramentas e caldeiraria para realizar conexões e fechos na montagem de equipamentos.

Normalmente, os nossos parafusos com olhal são fornecidos totalmente roscados para dispor de uma maior área de utilização.

Sob demanda, também podemos fornecer parafusos com olhal inoxidável, com outros acabamentos e especiais.



TORNILLOS CON OJO

DIN 444 EYE BOLTS • VIS À CÉIL • PARAFUSOS COM OLHAL

OpaC
14
elementos normalizados

DIN 444 (L)

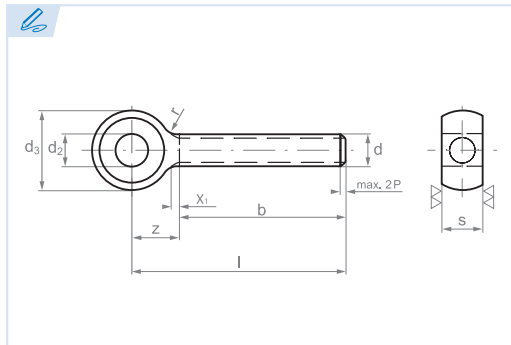

Tornillo con ojo totalmente roscado
Fully threaded eye bolt
Vis à œil filetage totale
Parafuso com olhal totalmente roscado

Calidad 8.8
Property class 8.8
Classe 8.8
Qualidade 8.8

Forma B (ejecución mg)
Form B (mg configuration)
Forme B (finition mg)
Forma B (execução mg)

d	M5	M6	M8	M10	M12	M16	M20	M24	• M27	M30	• M33	M36	• M39	d
P	0,8	1,0	1,25	1,5	1,75	2,0	2,5	3,0	3,0	3,5	3,5	4,0	4,0	P
b	Totalmente roscado · Fully threaded · Filetage total · Totalmente roscado													b
d2	H9 5	6	8	10	12	16	18	22	24* / 25	27* / 28	30	32 / 33*	35 / 36*	H9 d2
d3	máx. 12	14	18	20	25	32	40	45	50	55	60	65	70	máx. d3
	mín. 11,57	13,57	17,57	19,48	24,48	31,38	39,38	44,38	49,38	54,26	59,26	64,26	69,26	mín.
r	≈ 2,5	4,0	4,0	4,0	6,0	6,0	6,0	10,0	10,0	10,0	16,0	16,0	16,0	≈ r
s	máx. 6	7	9	12	14	17	22	25	27	30	34	38	41	máx. s
	mín. 5,88	6,85	8,85	11,82	13,82	16,82	21,79	24,79	26,79	29,79	33,75	37,75	40,75	mín.
z	máx. ≈ 11	14	16	18	23	27	32	40	42	46	54	59	61	máx. ≈ z
l	30	30	40	45	55	70	100	100	120	150	150	160	160	l
	35	35	45	50	60	75	110	110	130	160	160	180	180	
	40	40	50	55	65	80	120	120	140	180	180	200	200	
	45	45	55	60	70	90	130	130	150	200	200	220	220	
	50	50	60	65	75	100	140	140	160	220	220	240	240	
	55	55	65	70	80	110	150	150	180	240	240	260	260	
	60	60	70	75	90	120	160	160	200	260	260	280	280	
	65	65	75	80	100	130	180	180	220	280	280	300	300	
	70	70	80	90	110	140	200	200	240	300	300			
	75	75	90	100	120	150	220	220	260					
	80	80	100	110	130	160	240	240	280					
			90	110	120	140	180	260	260	300				
				120	130	150	200							
				130	140	160	220							
			140	150	180	240								
					200	260								
					220									
					240									
					260									

M	30	35	40	45	50	55	60	65	70	75	80	90	100	110	120	130	140	150	160	180	200	220	240	260	280	300	M
mín.	29,35	34,20	39,20	44,20	49,20	54,05	59,05	64,05	69,05	74,05	79,05	88,90	98,90	108,90	118,90	128,75	138,75	148,75	158,75	178,75	198,55	218,55	238,55	258,40	278,40	298,40	mín.
máx.	30,65	35,80	40,80	45,80	50,80	55,95	60,95	65,95	70,95	75,95	80,95	91,10	101,10	111,10	121,10	131,25	141,25	151,25	161,25	181,25	201,45	221,45	241,45	261,60	281,60	301,60	máx.

ES EN FR PT

P Paso de la rosca **Max 2P Máximo dos veces el paso de rosca (rosca incompleta)**
Pitch of thread Up to two times the pitch of thread (incomplete thread)
Pas de vis Maximum deux fois le diamètre de la vis (filetage partiel)
Passo da rosca Máximo duas vezes o passo de rosca (rosca incompleta)

Ref: ?

ejemplo
example
exemple
exemplo
Ref. = 444 - XX - XXX
DIN 444
M10x100
Ref. = 444-10-100



Las longitudes en negrita son las más utilizadas.
Bold numbers represent the most commonly used lengths.
En noir foncé les longueurs les plus utilisées.
Os comprimentos em negrito são os mais utilizados.

Se recomienda evitar estas medidas.
Avoiding these dimensions is recommended.
Nous déconseillons d'utiliser ces dimensions.
Recomenda-se evitar estas medidas.

X, según DIN 76 parte1
X, according to DIN 76 Part 1
X, suivant DIN 76 chap. 1
X, conforme a norma DIN 76 parte1

Tolerancia de la rosca 6g, según DIN 13.
6g thread tolerance according to DIN 13.
Tolérance du filetage 6g, suivant DIN 13.
Tolerância da rosca 6g, conforme a norma DIN 13.

* Si se requiere este diámetro de agujero, se debe especificar en el pedido.
* If you require this hole diameter, please specify this when placing your order.
* Si vous souhaitez ce diamètre de trou, veuillez le préciser lors de la commande.
* Se este diámetro de furo for necessário, deverá ser especificado no pedido.



DIN 444 (L) INOX

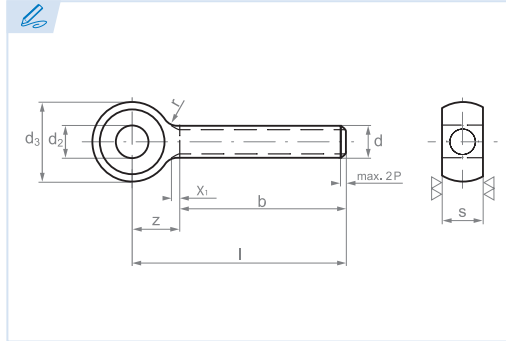
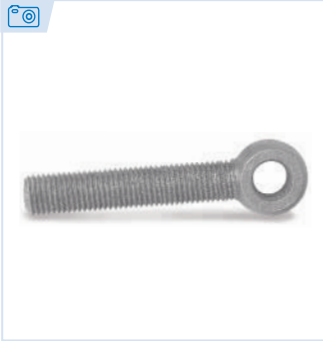

Tornillo con ojo totalmente roscado
Fully threaded eye bolt
Vis à œil filetage totale
Parafuso com olhal totalmente roscado

Acero Inoxidable
Stainless steel
Acier inoxydable
Aço Inoxidável

Forma B (ejecución mg)
Form B (mg configuration)
Forme B (finition mg)
Forma B (execução mg)

Artículo y medidas bajo consulta.
Item and dimensions by request.
Article et dimensions sur demande.
Artigo e medidas sob consulta.

Ref: ?

ejemplo
example
exemple
exemplo

Ref. = 4441 - XX - XXX
 d l

DIN 444 Inox.
M 10x100

Ref. = 4441-10-100

